

# Weightless Tank Scale Calibration

## Comparing Methods

**Calibration using test weights is impractical in large systems, such as storage tanks. Finding the most effective method and tools for calibration can be difficult because several factors may influence the calibration's accuracy. Using POWERCELL® CalFree Plus significantly reduces human error, therefore increasing accuracy.**

### Initial Calibration

Following tank installation, you must consider how to calibrate your device. Unlike off-the-shelf scale systems, tank scales are built from individual components. Each combination of components yields a different sensitivity that needs to be adjusted by calibration to achieve the final requirement. All individual components are pre-calibrated at the factory, but the combination (terminal, junction box, load cells and cables) is unique and nonetheless requires additional calibration.

Furthermore, many factors influence tank-scale calibration; some are predictable, and can be compensated using mathematical equations, while others are random or installation-specific and cannot be predicted or compensated for without weighing a known test weight. A mathematical method for weightless calibration can never be as accurate as one in which test weights are applied.



### Content

---

Initial Calibration

---

Traceability

---

Influences on Calibration

---

CalFree vs. CalFree Plus

---

## High vs. Low Traceability

Table 1 describes calibration methods with high and low traceability. A method should be chosen based on the impact and risk of an improper measurement. For example, a storage tank is considered low risk because the volume (weight) of the tank may not be critical to achieving high quality or safety.

Conversely, a mixing tank or reactor, where batches are executed, might have critical quality and safety ramifications, requiring a program with high traceability. Another example of the need for high traceability is when weighing product for business-to-business transactions. The method is user-driven and may vary from process to process based on risk and impact.

<b>High Traceability</b> <b>Calibration methods for tank scales</b>	<b>Low Traceability</b> <b>Calibration methods for tank scales</b>
<b>Methods</b> <ul style="list-style-type: none"> <li>• Test-weight calibration</li> <li>• RapidCal™ Tank Scale Calibration</li> <li>• Material substitution</li> <li>• Material transfer</li> <li>• Volumetric via flow-meter</li> </ul>	<b>Methods</b> <ul style="list-style-type: none"> <li>• CalFree Plus (PowerCell®)</li> <li>• CalFree (analog load cells)</li> <li>• Electrical calibration via load cell simulator</li> </ul>
<b>Typical applications:</b> <ul style="list-style-type: none"> <li>• Formulation</li> <li>• Batching</li> <li>• Filling</li> <li>• Dispensing</li> <li>• Use for trading</li> </ul>	<b>Typical applications:</b> <ul style="list-style-type: none"> <li>• Bulk storage tanks/silos</li> <li>• Level control</li> </ul>

**Table 1:** Typical applications and calibration methods.

## Influences on tank-scale calibration

### Influences that can be determined

The following parameters can be determined by calculation, but carry tolerances that lead to some uncertainty in the final calibration.

- Load-cell sensitivity is measured by most manufacturers and supplied along with each load cell. Therefore, the installer can precisely calculate the sensitivity of the final load-cell combination.
- Local gravity variations – see below picture - also can be accounted for in such calculations. Typically, the load cells are calibrated precisely at the manufacturing location. The difference in gravity from manufacturing to installation site – different GEO-Codes - can be estimated and compensated for. However, the gravity at the installation site may cause some uncertainty in the calculation.

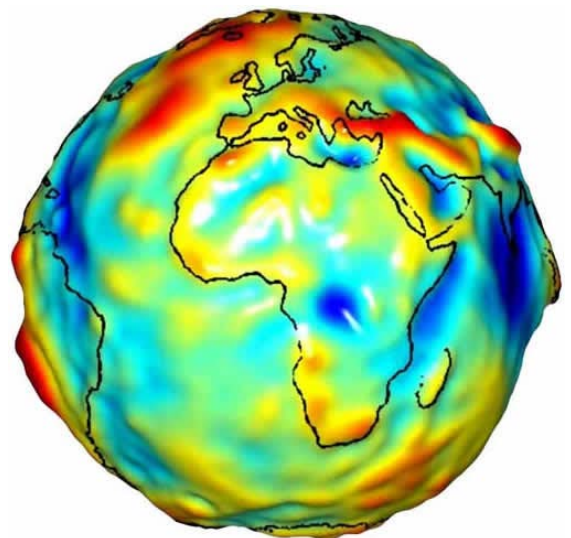

**Picture:** Earth Gravity Map

► [www.mt.com/tank-weighing](http://www.mt.com/tank-weighing)

## Random influences that cannot be determined

The following parameters cannot be determined easily or practically by calculation, and cannot be accounted for in the scale calibration.

### In General

- Mechanical load-cell and weigh module installation is often less than perfect. For example, if load cells are installed at an angle, their sensitivity is reduced. A 5-degree tilt leads to 0.4 percent error, but can be difficult to detect by the installer.
- Pipes attached to tank scales carry some proportion of the load that is weighed, effectively reducing scale sensitivity. If pipes are rigid, there will be a significant impact on calibration.

### Pertaining to Analog Systems only

- Analog junction boxes may have a significant impact on sensitivity. They require deep knowledge to provide a design that impacts the calibration as little as possible.
- Safety barriers used to separate intrinsically safe and non-intrinsically safe circuits in hazardous-area installations introduce resistance into analog circuits and have a major impact on the sensitivity of the load-cell system.
- Analog cables may have a significant impact on scale sensitivity. Typically, these impacts can be avoided using technical features, such as SENSE, on the terminal, and by using six-wire home-run cables and calibrating the load cell's cable.

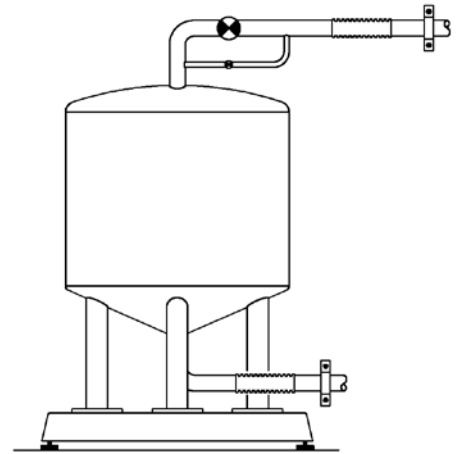

**Picture:** Piping can influence weightless calibration

However, some cable effects cannot be compensated for, such as the impact of the AUX cable, interconnecting multiple junction boxes and the complex impact of cable capacitance and inductance on the overall system accuracy.

- Analog load cells have an unavoidable tolerance – as specified in the datasheets. These are kept as low as technically possible, but tolerances remain. Connecting components leads to some small uncertainty with regard to corner error and final sensitivity. That effect is typically low, but if not compensated for, the impact may be significant.

► [www.mt.com/tank-weighing](http://www.mt.com/tank-weighing)



## Weightless Calibration Methods

All weightless calibration methods provide algorithms that perform calculations within known parameters, but do not cope well with unknown tolerances and random influences. Thus, the tighter the component

tolerances and less random influences there are, the more precise the result. The following table compares the two major low traceability methods, CalFree and CalFree Plus:

Impact on calibration	Type	CalFree Analog	CalFree Plus PowerCell®	Comment
Melting/crystallization	Known	Tolerance < $\pm 0.02\%$	Tolerance < $\pm 0.01\%$	Assuming actual calibration value is taken from the analog load cell certificate.
Geo Code	Known	Tolerance < $\pm 0.01\%$ Needs manual calculation	Tolerance < $\pm 0.01\%$ Automatically calculated	MT-Geo code applied to the calculation; if neglected, the error can go up to 0.4%.
Mechanical effects	Random	Very difficult to estimate, typically 0.1%		Can be significant if system is not correctly installed or rigid piping is applied to the tank.
Precision Analog Junction Boxes	Random	Estim. 0.02%	0% None	Due to corner-error and resistor tolerance, can go up to 2% with other J-box principles.
AUX cable	Random	Estim. 0.02%	0% None	Avoid AUX cable whenever possible
Cable capacitance and impedance effects	Random	Very difficult to estimate Estim. 0.02%	0% Digital signal transfer thus no impact	
Analog LC tolerances	Random	0.1%	0% No impact	Impact on connecting analog load cells in parallel and un-corrected corner error
Best case scenario		0.16%	0.1%	Root Sum Square combination of individual errors
Worst case scenario		2%	0.1% Fully automatic	CalFree risk if wrong junction-box or LC sensitivity used, and not applying Geo Code

**Table 2:** Comparing CalFree vs. CalFree Plus

## Conclusion

The design of CalFree is based on analog load cells and all mentioned impacts. Its accuracy is limited to a typical value of 0.16 percent and higher. If the installer uses the wrong junction box, does not apply the GEO code and takes the nominal, instead of the actual, load-cell sensitivity for the calculation, the error can increase to 2 percent. Thus, analog CalFree requires an experienced installer and diligence in selecting the correct components.

CalFree Plus with POWERCELL® is advantageous because it lowers load-cell tolerance and avoids

random impacts as much as possible. Furthermore, human error is avoided completely as calculations are completed automatically in the terminal. That leads to a typical accuracy value of 0.1 percent.

### Summary

Weightless calibration methods provide low-traceability calibration of tank scales and can result in accuracy from 0.1 and 2 percent depending on the method used and human error. POWERCELL® CalFree Plus guarantees the use of the correct components while avoiding human error completely, leading to higher accuracy.

[www.mt.com/ind-tank-weighing](http://www.mt.com/ind-tank-weighing)

For more information

#### METTLER TOLEDO Group

Industrial Division

Local contact: [www.mt.com/contacts](http://www.mt.com/contacts)



Subject to technical changes

©01/2019 METTLER TOLEDO. All rights reserved

Document No. 30388116

MarCom Industrial